

Communications & Power Industries Coaxial Magnetron



FEATURES:

- Frequency 8.5 – 9.6 GHz
- Peak power output 325 kW
- Duty cycle .001
- Anode voltage 29 kV
- Anode current 30 amps
- Pulse width 3.5 microseconds
- Heater 9 volts @ 14 amps
- Air cooled
- Mechanically tunable

BENEFITS:

- Long life
- Exceptional frequency stability

APPLICATIONS:

- Threat simulator radars
- Weather radars

CPI X-Band 325 kW Coaxial Magnetron: VMX1131

Electrical Specifications

Frequency	8.5 – 9.6 GHz
Peak power output	325 kW
Average power output	0.325 kW
Pulse voltage	27 – 30 kV
Peak anode current	35 A
Average anode current	30.0 mA
Pulse width	3.5 μ S
Duty cycle	0.001
Maximum filament voltage	10 V
Maximum filament current	50 A
Minimum warm-up time	180 S
Maximum load VSWR	1.3:1

Mechanical and Environmental Specifications

Cooling	Forced air
Maximum body temperature	125°C
Mounting position	Any
Support	Mounting flange
Coupling	WR112
Tuning	146
Weight	18 lbs. (8.16 kg)

With a history of producing high quality products, we can help you with your magnetron.

Contact us at BMDMarketing@cpii.com or call us at +1 978-922-6000.

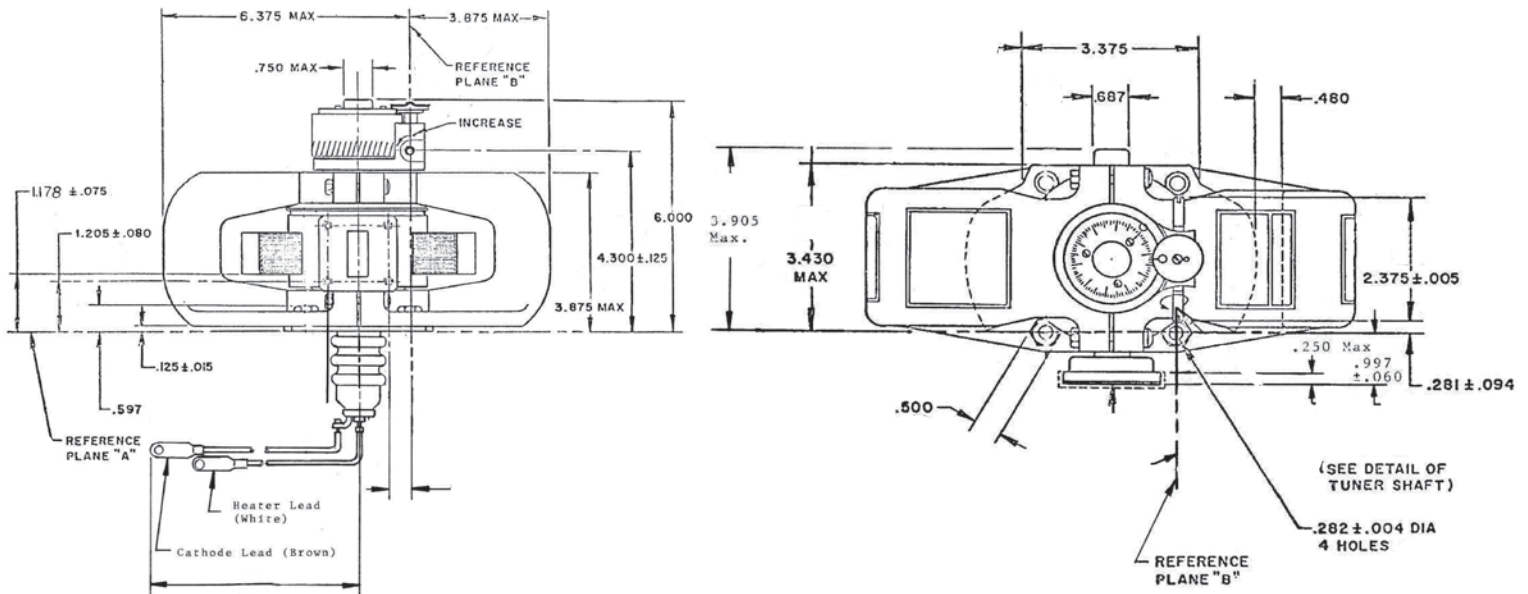

Beverly Microwave Division
 150 Sohier Road
 Beverly, Massachusetts
 USA 01915

tel +1 978-922-6000
 email BMDMarketing@cpii.com
 fax +1 978-922-8914
 web www.cpii.com

For more detailed information, please refer to the corresponding CPI technical description if one has been published, or contact CPI. Specifications may change without notice as a result of additional data or product refinement. Please contact CPI before using this information for system design.

©2020 Communications & Power Industries LLC. Company proprietary; use and reproduction is strictly prohibited without written authorization from CPI.